



Mustang Sampling[®]

Mustang[®] Vaporizer Installation, Operation & Maintenance

MV[®]



TABLE OF CONTENTS

Safety Warnings	3
Product Features	4
Technical Specifications	5
Product Dimensions & Parts	6
Electrical Wiring Diagrams	8
Installation Instructions	10
Operation Instructions	11
Maintenance Instructions	11

SAFETY WARNINGS



Failure to abide by any of the safety warnings could result in serious injury or death.

- Industrial Control Equipment (UL 508)
- Industrial Control Equipment (CSA C22.2 No. 14)
- Explosion Proof and Dust-Ignition-Proof Electrical Equipment for use in Hazardous (Classified) Locations (UL 1203)
- Explosion Proof Enclosures for use in Class 1 Hazardous Locations (CSA C22.2 No. 30)
- Electric Heaters for use in Class 1 Hazardous (Classified) Locations (UL 823)
- Sealing fitting must be installed with access allowing the dams to be made and the sealing compound to be properly poured.
- Electrical power must be “**OFF**” before and during installation and maintenance or personal injury may result.
- Do not exceed any equipment pressure ratings.
- Surface temperatures will approach temperature limit specified in technical specifications. Gloves may be required for handling or adjustment.
- Select a mounting location so that the enclosure will not be subjected to impact by heavy objects. Impacts can damage enclosed devices.
- The hazardous location information specifying class and group listing on each instrument enclosure is marked on the nameplate of each enclosure.
- All unused conduit openings must be plugged. Plugs must be a minimum of 1/8” thick and engage a minimum of 5 full threads.

CAUTION: TO REDUCE THE RISK OF FIRE OR EXPLOSION, DO NOT INSTALL WHERE THE MARKED OPERATING TEMPERATURE EXCEEDS THE IGNITION TEMPERATURE OF THE HAZARDOUS ATMOSPHERE(S).

ATTENTION: POUR RÉDUIRE LE RISQUE D’INCENDIE OU D’EXPLOSION, NE PAS INSTALLER LÀ OÙ LA TEMPÉRATURE DE FONCTIONNEMENT MARQUÉE DÉPASSE LA TEMPÉRATURE D’INFLAMMATION DE L’ATMOSPHÈRE OU DES ATMOSPHÈRES DANGEREUSES.

PRODUCT DESCRIPTION

The Mustang Vaporizer (MV®) flash vaporizes liquid samples for introduction into gas analysis systems. Liquid samples are maintained near line conditions until reaching a flash chamber within the vaporizer, preventing pre-vaporization. The energy for vaporization is provided by an electric cartridge heater with sufficiently large surface area to maintain a stable gas temperature throughout the process.

APPLICATION

The Mustang Vaporizer is designed for flash vaporization of liquid samples including Liquefied Natural Gas (LNG), Natural Gas Liquids (NGL), or other cryogenic liquids in petrochemical, refinery, liquefaction, or natural gas processing plants.

FEATURES

- Thermal cutoff
- Versatile conduit connections
- Integral heater and controller
- Integral flow restrictor on inlet
- Compatible with Mustang Intelligent Vaporizer Sampling System® - Model 1 & 2 for LNG

BENEFITS

- Heater cartridge does not contact sample fluid
- Provides five times more heat transfer capacity than vaporizing regulators
- Uniform liquid flash vaporization
- No premature flashing or partial fractionation

TECHNICAL SPECIFICATIONS

Maximum Allowable Working Pressure	3500 psig (241.3 bar)
Proportional Temperature Control Range	0 to 500°F (-17 to 260°C)
Port Sizes	1/4" female NPT
Conduit Connection	3/4" female NPT
Internal Volume	40 cc
Thermal Cut-off	Normally opens at 284°F (140°C) (other ranges available upon request)
Wetted Materials	Machined parts: 316 stainless steel/NACE compliant All other metal parts: stainless steel/NACE compliant
Electrical Enclosure Classification	Class 1, Division 1 & 2, Groups C, D, T3
Controller	Watlow®
Input Supply Voltage	115 VAC , 415 Watts, 50/60 Hz 208/230 VAC , 415 Watts, 50/60 Hz
Seal	Viton® Kalrez® other materials available upon request
Certification	C - cETLus

PRODUCT DIMENSIONS & PARTS

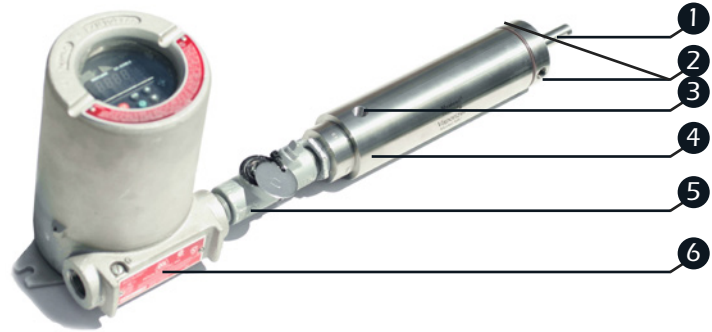

BILL OF MATERIALS		
Item Number	QTY	Description
1	1	Flow Adjuster
2	2	Inlet Port (Optional Speed Loop)
3	1	Outlet Port
4	1	Flash Vaporization Chamber Contains: Heater; Cartridge, 350W/120V/208V/230V Thermocouple; Type J (2) Cut Off Switch; Thermal, Selco, P/N UP61-110C OR UP61-130C Enclosure; Killark GR0M0D 4GRB CEN OR Equal Wire; High Temp Heat Shrink Boot; Teflon, Small 2" Heat Shrink Boot; Teflon, Large
5	1	Sealing Fitting; Rated Exd IIC by Notified Body Nipple; 3/4", Rigid Conduit, Close Nipple; Threaded, Rigid Conduit, 2" Long
6	1	Temperature Controller Bracket; Controller

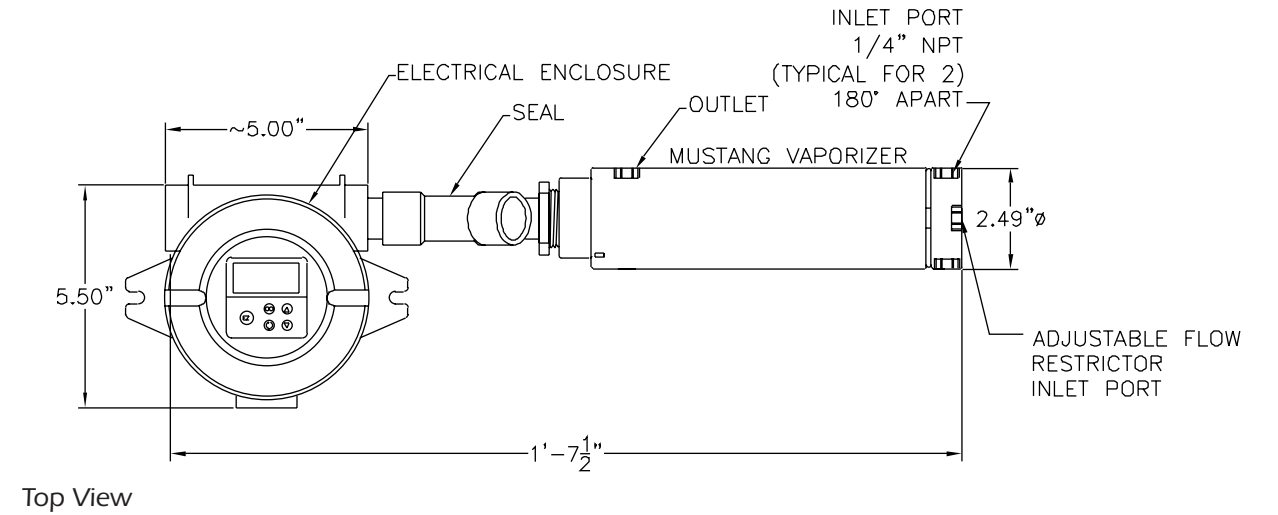
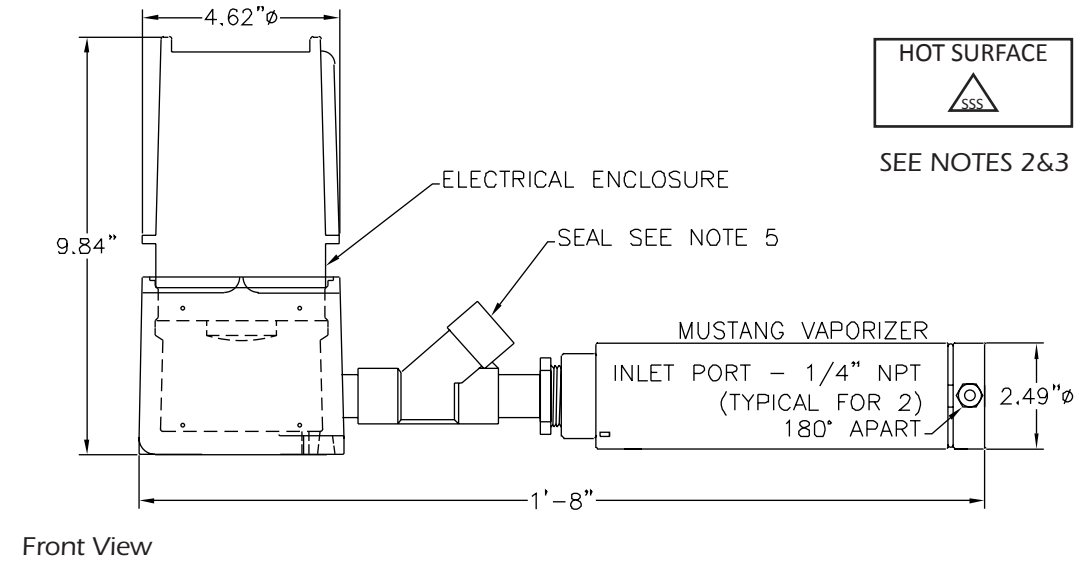

NOTES:

1. ASSEMBLY IS THE SAME FOR ALL VOLTAGES (120/208/230 VAC).
2. TAG HOT SURFACE.
3. TAG IS MARKED ON 304 OR 316 SS BY ETCHING OR OTHER MEANS.
4. HAZARD LOCATION ENCLOSURE SPECIFICATIONS ARE ON DWG #MST-GRB-LABEL.
5. CONDUIT SEAL FITTING TO BE POURED BEFORE PLACING IN A HAZARDOUS AREA SERVICE.

TEMPERATURE CONTROLLER ENCLOSURE SPECIFICATION

Outlet box for hazardous locations

Class 1, Groups B, C, D
CE Ex 11 2 g Ex d IIC. T6-30 Max, T5-40 Max Gb IP66

CAUTION: TO REDUCE THE RISK OF IGNITION OF HAZARDOUS ATMOSPHERES, DISCONNECT THE EQUIPMENT FROM THE SUPPLY CIRCUIT BEFORE OPENING. KEEP ASSEMBLY TIGHTLY CLOSED WHEN IN OPERATION.

ELECTRICAL & WIRING DIAGRAMS

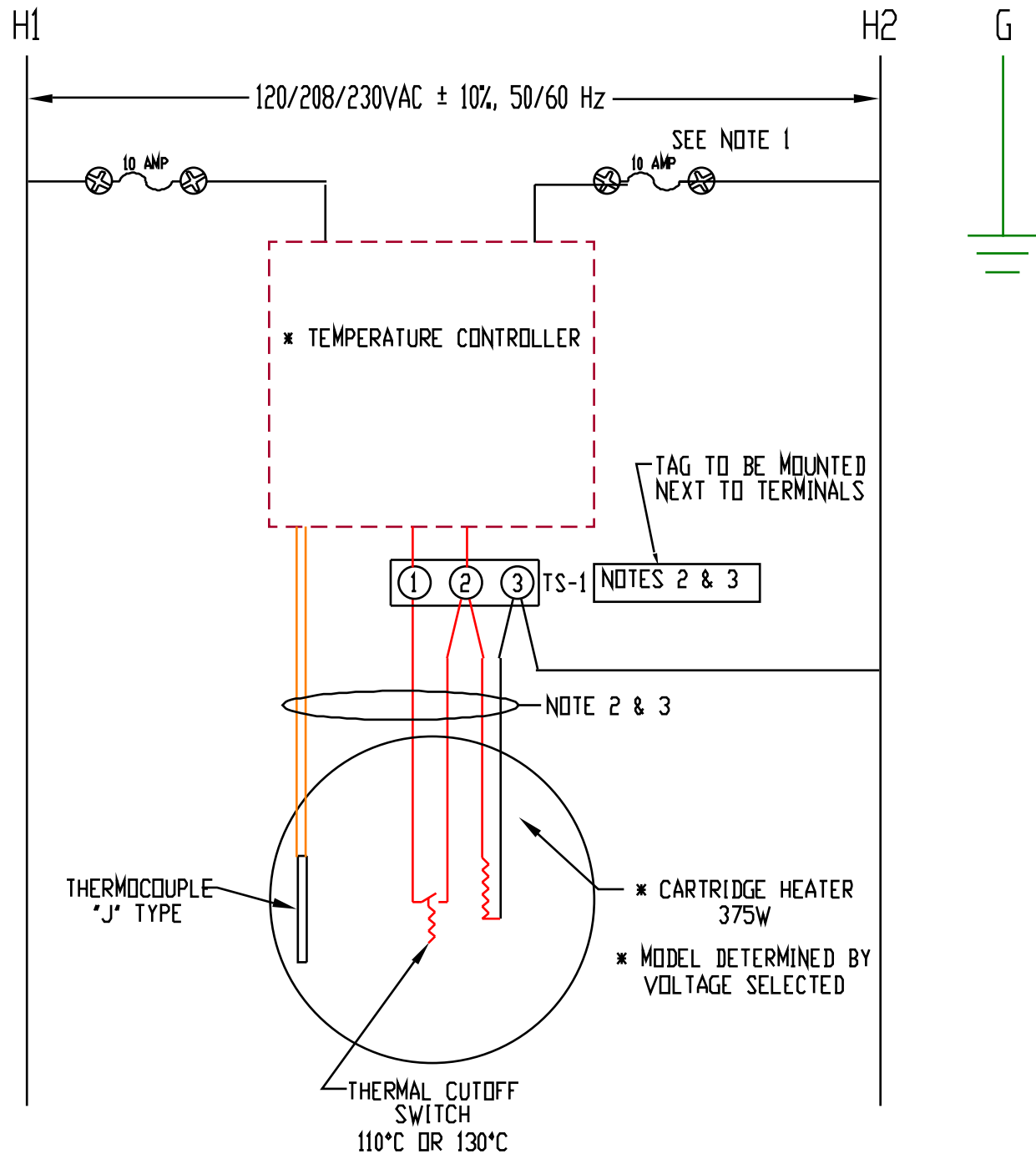

NOTES:

1. PRESENT IF 208V OR 230V IS SELECTED.
2. ALL WIRING TO HEATER MUST MEET OR EXCEED MINIMUM INSULATION REQUIREMENTS.
3. WIRE INSULATION TO BE RATED AT MINIMUM 200°C OR HIGHER, TYPE FEPB, PFA, TFE, FIBERGLASS.

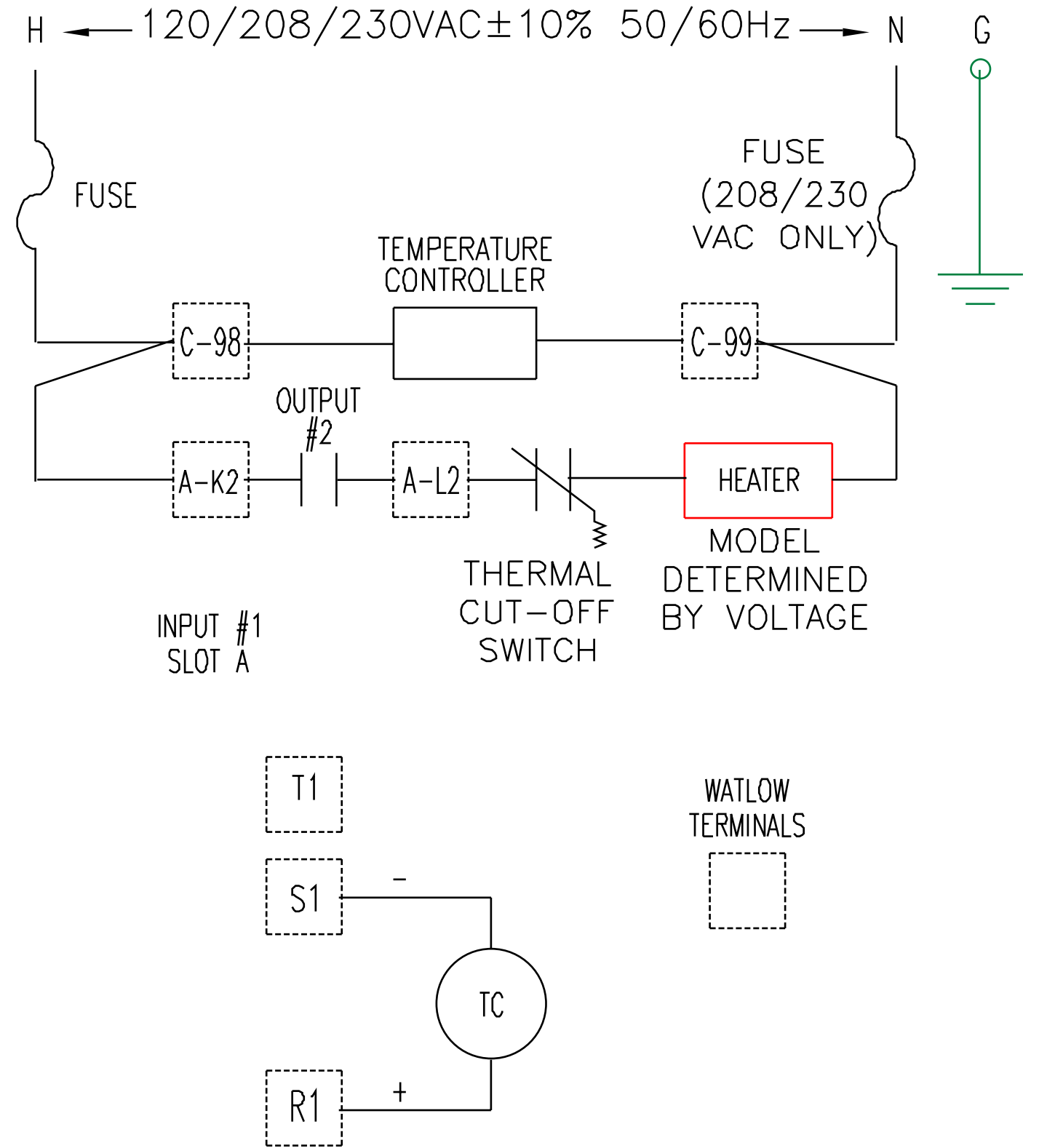

INSTALLATION INSTRUCTIONS

NOMENCLATURE

- **MAOP**—Maximum Allowable Operating Pressure
- **LNG**—Liquid Natural Gas
- **BTU**—British Thermal Unit

TOOLS REQUIRED

- Standard Hand Tools
- Battery Powered Impact Wrench

INSTALLATION

1. The MV[®] is mounted in a vertical position with the sample flowing down through the unit.
2. Connect the tubing inlet and outlet fittings to the respective ports. Plug any unused ports.
3. Mount the MV assembly in accordance with previous cautions and warnings.
4. Perform the electrical hook up with de-energized conductors.
5. Verify the unit that you are hooking up to matches voltage wise with the power supply that you are connecting. Damage to the unit can occur if the wrong source power is applied.
6. A seal fitting is required for the power input connection to the controller enclosure to maintain its electrical hazard classification rating.
7. For 120 volt single phase input power: connect the “hot” wire to wiring terminal #1. Connect the “Neutral” wire to wiring terminal #2. Connect the earthing (ground) wire to the green screw in the bottom of the enclosure.
8. For 208 or 230 volt single phase input power: connect one “hot” wire to wiring terminal #1. Connect the “Neutral” to wiring terminal #2. Connect the second “hot” wire to wiring terminal #2. Connect the earthing (ground) wire to the green screw in the bottom of the enclosure.
9. A seal fitting is required between the controller enclosure and the MV.
10. Externally connect earthing (grounding) conductors from assembly to equipment ground connections.
11. Connections from the controller to the vaporizer are pre-wired from the factory. If replacement or troubleshooting is required, refer to the electrical schematic supplied with the unit.

ADJUST THE TEMPERATURE SET POINT

The temperature controller comes from the factory set to 250°F (121°C) unless otherwise specified. If a different temperature is required, refer to the Watlow[®] Temperature Controller operation manual for the complete setup and adjustment procedures.

START-UP PROCEDURE

1. Close the cover on the controller enclosure.
2. Turn on the electrical supply to the controller.
3. Allow a few minutes for the system temperature to stabilize.
4. Seal the conduit seal fittings if the controller is functioning as desired.

OPERATION INSTRUCTIONS

1. Verify that the sample stream supply is shut off.
2. Verify that the power to the controller is off.
3. Install the Watlow supplied software (EZ-ZONE[®] Configurator) on a laptop or other computer.
4. Connect to the Watlow controller using a RS-485 adapter (B&B Electronics Model 485SD9 TB or equal). Plug the adapter into the serial port. Select the serial port on the computer to be used (i.e. COM 1-COM17). The other end connects to the RS-485 terminals.
5. On the computer, start program “EZ-ZONE Configurator.”
6. Turn power on to the controller.
7. Establish communication with the Watlow controller.
8. Set its address to “1” or user preference.
9. Set the regulator temperature set point to the recommended temperature.
10. Set the vaporizer temperature set point to the recommended temperature.
11. For all other Watlow parameter settings, refer to the EZ-ZONE User’s Manual.
12. Slowly turn in the sample fluid low to full open to the regulator.
13. Adjust the regulator adjusting screw to obtain the desired output pressure.
14. Once sample fluid is being regulated, monitor the regulator temperature to verify that the controller is maintaining the set point temperature.
15. Verify the pressure and flow to the remote gas chromatograph or analyzer.
16. Once the flow is correctly established to the analyzer or gas chromatograph, document the flow value. Do not adjust the flow value unless a calibration check is made on the analyzer.
17. Do not leave power on for extended periods of time without flow through the unit.

MAINTENANCE INSTRUCTIONS

1. Once system is operational, no routine maintenance is required.
2. Monitoring of flow and temperature values is recommended at least annually.

Analytically Accurate® **TECHNOLOGY**

About Mustang Sampling

Mustang Sampling, LLC is the innovator of Analytically Accurate® solutions within sample conditioning systems. We provide custom solutions of products and services globally to the Natural Gas, Natural Gas Liquids (NGL), Renewable Natural Gas (RNG), Liquefied Natural Gas (LNG) industries including Hydrogen Blending and Carbon Sequestration. Mustang Sampling continues to pioneer integrated control systems, allowing our customers to maintain phase stability from sample extraction at the source through sample analysis. Our products are continuously improved and subjected to the highest quality standards which provides our customers with the best sample conditioning solutions.

Mustang Sampling, LLC
43 Ritmore Glen
Ravenswood, WV 26164
P: +1 304 273 5357
F: +1 304 273 2531

info@MustangSampling.com
www.MustangSampling.com

Copyright © 2017-2022 Mustang Sampling.
All rights reserved.
Mustang Sampling®, Mustang®, MV®, Mustang Intelligent Vaporizer Sampling System® and Analytically Accurate® are registered trademarks of Mustang Sampling, LLC
Kalrez® is a registered trademark of DuPont.
Viton® is a registered trademark of Chemours.
Watlow® and EZ-ZONE® are registered trademarks of Watlow.

No part of this publication may be reproduced in any material form without the written permission of Mustang Sampling, LLC.

MS-IOMMV.v6-EN-P June 2022
Supersedes: MS-IOMMV.v5-EN-P