



Mustang Sampling[®]

Mustang[®] Heated Regulator

MHR[®]

The Mustang Heated Regulator (MHR[®]) prevents liquid condensation from Joule Thomson cooling in natural gas mixtures when pressure reduction is required.

The process temperature is controlled using PID logic throughout the pressure reduction cycle with both pre- and post-regulation heat exchangers along a tortuous path. The final process pressure is set manually using an adjustable regulator control across a specified range.



APPLICATION

The MHR assembly provides safe and reliable temperature control and pressure reduction essential to ensuring the performance of gas analyzers.



Natural Gas

FEATURES

- Temperature Controller in Class 1, Division 1 & 2, or Zone 1 Exd Enclosure
- Proportional-Integral-Derivative (PID) controller
- Single-stage design
- Piston pressure sensing elements
- 20 micron inlet filter
- Unique Heat Exchange Chamber
- Two section design for easy disassembly from heat plate attachment
- Adjusting Screw with lock nut

BENEFITS

- Offsets Joule-Thomson cooling providing continuous gas sample conditioning
- Protects analyzers & helps preserve sample integrity
- Prevents condensation
- Minimizes regulator freeze ups
- Maintains outlet pressure during large inlet pressure swings
- Easy to mount in small or densely populated enclosures



PRODUCT DIMENSIONS

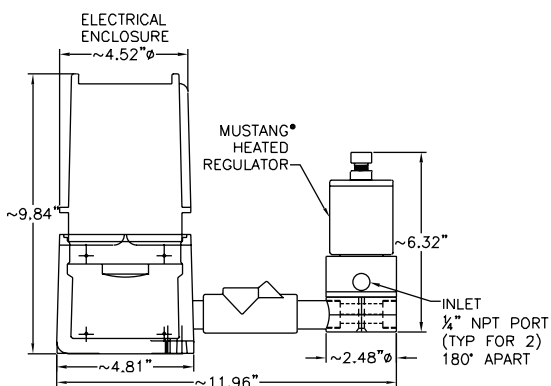

Side View

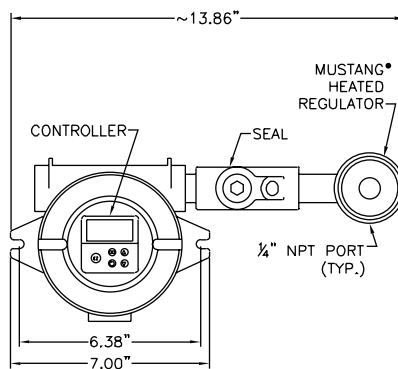

Top View

PRODUCT SPECIFICATIONS

Maximum allowable working pressure	3750 psig (258 bar)
Temperature range	-15°F to 300°F (-26°C to 149°C)
Port sizes	1/4" female NPT
Wetted materials	Machined parts: 316 stainless steel/NACE compliant All other metal parts: stainless steel/NACE compliant
Conduit connection	3/4" female NPT
Internal volume	5 cc
Cv Coefficient	0.023
Thermal cut-off	Normally opens at 284°F (140°C) (other ranges available upon request)
Electrical enclosure classification	Class 1, Division 1 & 2, Groups B, C, D
Temperature Controller	Watlow® PID Temperature Controller Oven Industries
Outlet pressure range	0-10 (0-0.69 bar) 0-25 (0-1.72 bar) 0-50 (0-3.45 bar) 0-100 (0-6.89 bar) 0-250 (0-17.24 bar) 0-500 (0-34.47 bar)
Input Supply Voltage options	115 VAC, 215 Watts, 50/60 Hz, ± 10% 208/230 VAC, 215 Watts, 50/60 Hz, ± 10% 24 VDC, 155 Watts
Seals	James Walker Viton® Kalrez® other materials available upon request
Certification	C - cETLus A - Atex/IECEX

Use the bold alpha-numeric characters from the table above to build your model number:



Analytically Accurate® TECHNOLOGY

About Mustang Sampling

Mustang Sampling, LLC is the innovator of Analytically Accurate® solutions within sample conditioning systems. We provide custom solutions of products and services globally to the Natural Gas, Natural Gas Liquids (NGL), and Liquefied Natural Gas (LNG) industries. Mustang Sampling continues to pioneer integrated control systems, allowing our customers to maintain phase stability from sample extraction at the source through sample analysis. Our products are continuously improved and subjected to the highest quality standards which provides our customers with the best sample conditioning solutions.

Mustang Sampling, LLC
43 Ritmore Glen
Ravenswood, WV 26164
P: +1 304 273 5357
F: +1 304 273 2531

info@MustangSampling.com
www.MustangSampling.com

Copyright © 2017-2019 Mustang Sampling. All rights reserved. Mustang Sampling®, Mustang®, MHR® and Analytically Accurate® are registered trademarks of Mustang Sampling, LLC. Watow® is a registered trademark of Watlow. Kalrez® is a registered trademark of DuPont. Viton® is a registered trademark of Chemours.

No part of this publication may be reproduced in any material form without the written permission of Mustang Sampling, LLC.

MS-CSMHR.v6-EN-P September 2019
Supersedes: MS-CSMHR.v5-EN-P