

MPRVSS



Mustang Sampling®

Mustang® Pressure Regulating Vaporizer Sample Conditioning System

Item Number	Description
1	Manual Liquid Pressure Regulator
2	Single Path Vaporizer
3	Power Input
4	RS-485 Communications
5	Dual Temperature Controllers
6	SS Insulated Enclosure
7	Outlet
8	Single or Multi-Stage Heated Regulator
9	Heated Liquid Block
10	Drain

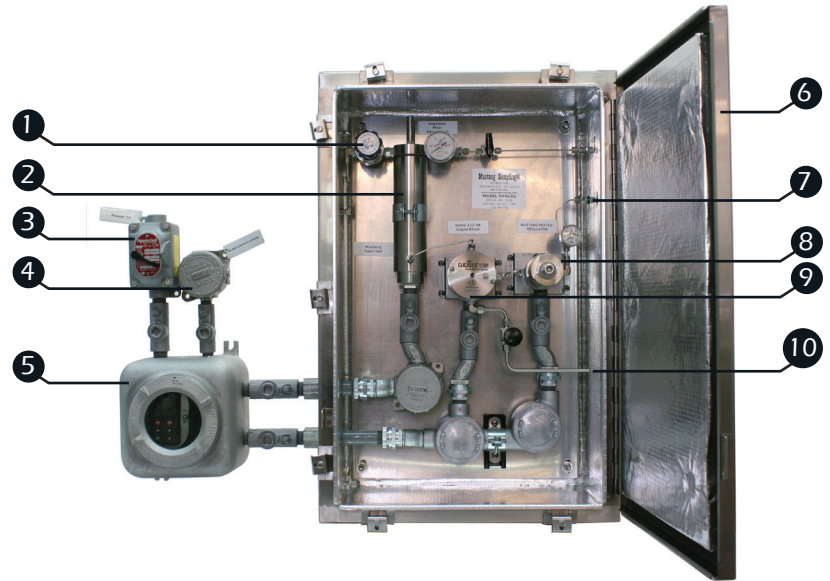

APPLICATION

The Mustang Pressure Regulating Vaporizer Sample Conditioning System (MPRVSS) combines a Mustang® Vaporizer and Mustang® Heated Regulator with a PID temperature controller and a Genie® Supreme 123HP liquid block to create a robust, single-path sample conditioning system for natural gas liquids.

A representative sample is delivered to a flash chamber within the vaporizer, preventing pre-vaporization. An independently controlled electric cartridge heater, with sufficiently large surface area, maintains a stable gas temperature throughout the process. The Genie Supreme 123HP eliminates entrained liquids and particulates at high pressure. Pre- and post-regulation heat exchangers, along a tortuous gas path in the Mustang Heated Regulator, ensure sample and phase stability for introduction into natural gas analyzers. The Mustang Pressure Regulating Vaporizer Sampling System is available with dual Mustang Vaporizers if redundancy is required.



NGL

FEATURES

- Patented technology
- Continuous gas flow design
- Vented cabinet having a gas sample input
- Dual temperature controller
- Pressure regulator
- Single path vaporizer
- Liquid block
- Heated regulator

BENEFITS

- Provides an accurate and reliable representative sample to the Gas Chromatograph
- Eliminates post-vaporization hydrocarbon liquid dropout
- Reduces the incoming liquid pressure
- Eliminates the presence of any remaining liquid in the natural gas sample
- Able to condition a wide range of liquids



PRODUCT DIMENSIONS

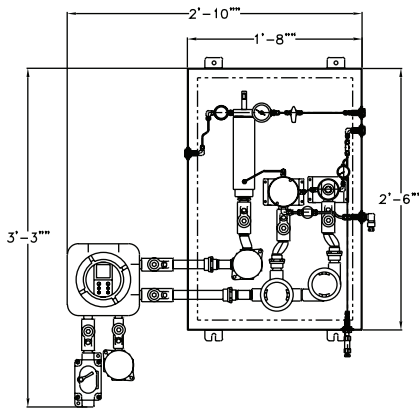

Front View

PRODUCT SPECIFICATIONS

Maximum Allowable Operating Pressure	3750 psig (359 bar)
Proportional Temperature Control Range	0°F to 300°F (-18°C to 148°C)
Port Sizes	1/4" female NPT
Conduit Sizes	3/4" female NPT
Electrical Enclosure Classification	Class 1, Division 1 & 2, Groups C, D, T3
Wetted Materials	Machined parts: 316 stainless steel/NACE compliant All other metal parts: stainless steel/NACE compliant (other materials available upon request)
Power Rating Options	115 VAC , 815 Watts, 50/60 Hz, ± 10% 208/230 VAC , 815 Watts, 50/60 Hz, ± 10%
Regulator	MHR Single Stage Regulator MJTHR Multi-Stage Regulator

Use the bold alpha-numeric characters from the table above to build your model number:

MPRVSS - -
 Power Rating / Regulator

SAMPLE CONDITIONING STAGES

- **STAGE 1**—Single-path unit designed to flash vaporize NGL
- **STAGE 2**—A Genie® Supreme Model 123HP utilizes innovative Liquid Block Technology™ to remove 100% of entrained liquid and particulate in a gas sample
- **STAGE 3**— A pre and post-heated pressure regulator designed to prevent hydrocarbon dew point dropout and reduce sample pressure which is then delivered to the heated liquid block.

Analytically Accurate® TECHNOLOGY

About Mustang Sampling

Mustang Sampling, LLC is the innovator of Analytically Accurate® solutions within sample conditioning systems. We provide custom solutions of products and services globally to the Natural Gas, Natural Gas Liquids (NGL), and Liquefied Natural Gas (LNG) industries. Mustang Sampling continues to pioneer integrated control systems, allowing our customers to maintain phase stability from sample extraction at the pipeline through sample analysis. Our products are continuously improved and subjected to the highest quality standards which provides our customers with the best sample conditioning solutions.

Mustang Sampling, LLC
 43 Ritmore Glen
 Ravenswood, WV 26164
 P: +1 304 273 5357
 F: +1 304 273 2531

info@MustangSampling.com
 www.MustangSampling.com

Copyright © 2017 Mustang Sampling. All rights reserved. Mustang Sampling®, Mustang® and Analytically Accurate® are registered trademarks of Mustang Sampling, LLC. Genie® is a registered trademark of A+ Corporation.

U.S. Patent 9,285,299

No part of this publication may be reproduced in any material form without the written permission of Mustang Sampling, LLC.

MS-CSMPRVSS.v2-EN-P April 2017
 Supersedes: MSBC-MPRVSS-CE VOL.1.1